

METAL ENCLOSED CAST-RESIN BUSWAY SYSTEM

DELTA BAR®

MV/LV BUSWAY SYSTEMS

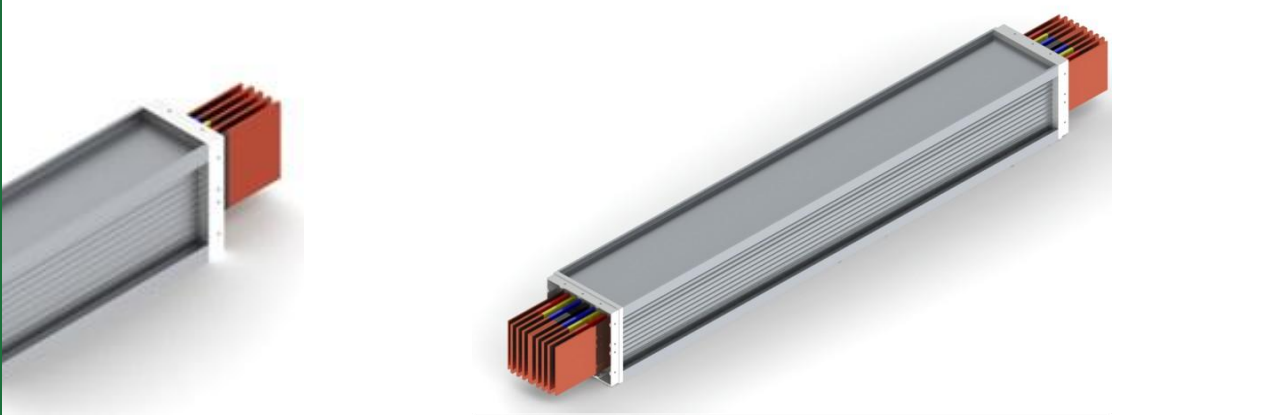

KEMA Quality CE



ISO 9001: 2008

REGISTERED FIRM
CERT.NO:- ME/08/1149

CONTENTS

	PAGES
1. Introduction	3
2. Construction	4
3. Salient Features	5
4. Technology	6
5. Manufacturing & Quality Assurance	7
6. Technical Data Sheets	8-10
7. Voltage Drop Values	11-12
8. Straight Length Feeder	13
9. Elbows	14
10. Flanges	15
11. Joints	16
12. Supports	17
13. Expansion Joints	18
14. Plug-In Units	19
15. Design Validation	21
16. Test Certificates	22-25
17. Typical Installation	27

INTRODUCTION

DELTA ELECTRIC(FZE) established in 2007 in the SAIF ZONE Sharjah Emirate of the United Arab Emirates, manufacture KEMA Quality (DEKRA) Certified Low Voltage Busway Systems - **DELTABAR**. From 800A up to 3200A and multiplies beyond and Medium Voltage Busway System – **DELTABAR M** – Phase Segregated OR Non-Segregated up to 12kV

DELTA ELECTRIC is an ISO 9001: 2008 Certified Company since 2008, ensuring that our Product Designs, Process, Quality Systems and Procedures are International Standards

PRODUCT:

DELTABAR

Brand of IP68 Rated Busway Systems from 800A to 3200A (single run feeder Elements), 4000A and above (with multiple Feeder Elements), Feeder elements with tap off provision - IP 68 Rated, Life time Maintenance free, with Plug-in Tap- Off Units (IP66 rated) up to 1250A .

The unique low Voltage Busbar Systems –**DELTABAR** are designed & developed by **DELTA ELECTRIC**, the designs are validated and certified by KEMA Quality (DEKRA Certified)Netherlands, after type tests from 800A to 5000A as per IEC 60439-1 & 2.

DELTABAR Busway System, combines in it, all the advantages, at the same time making up or dispensing with all disadvantages and/or shortcomings, of all other designs which are now familiar to the market, thus making it truly unique from all angles of rigidity, functionality, versatility, quality, maneuverability and aesthetics.



CONSTRUCTION

Enclosure :-

The full range of Busbar trunking systems - ratings of 800A up to 3200A are grouped in 2 frame sizes, decided by the external cross-sectional dimensions of the extruded Aluminum tubular enclosure.

Frame Size 1: Having an overall cross-sectional size of 125x185; accommodating single copper conductor per phase, of varying thicknesses and uniform width, to cater to the varying current ratings of 800A to 1600A.

Frame Size 2: Having an overall cross-sectional size of 185x185; accommodating separately positioned double copper conductors per phase, of varying thicknesses and uniform width, to cater to the varying current ratings of 2000A to 3200A.

Combination Frame Size: For ratings above 3200A, a combination of 2 or more parallel runs of Frame Size 2 feeder elements will form one feeder element of the particular rating.

Insulation :-

The uniform spacing between the conductors, within the extruded Aluminium enclosure is filled with a special resin-filler mix of high mechanical and electrical strength, and specific thermal characteristics. A special test as per **DELTA ELECTRIC** Specification, was conducted and certified by KEMA, to assess the **THERMAL With-standability** of the Cast-Resin Insulating Material, by subjecting the Conductors of the Feeder Element to minimum **185°C for 3 hours**



Thermal With-Standability Test Setup

Conductors :-

The conductors are High Conductivity Electrical Grade Copper Flats of cross-sectional area, more than sufficient to with-stand the electrodynamic and thermal requirements.

Phase identification heat shrinkable sleeves of high quality (thermal and insulation properties) are used, for convenience while manufacturing and during erection.

Joints :-

Exclusively designed phase barriers segregates the fish plates and are rigidly and externally clamped by 2 sets of steel clamps and bolts, each set comprising 2 clamps, 2 bolts and 2 lock nuts.

The joints are enclosed by Aluminum covers fixed by bolting the ends of mating feeder elements, and the internal cavities permanently filled, by the same resin mix used for the feeder elements.

Plug in Tap-off units :-

All the tap off units are plug in type, for the full range up to 1250A, as standard & 1500A optionally.

Plug In units are taken up inclined, the top end towards the feeder elements, hooked on to pins on the feeder element, and bottom end pushed on to the feeder element, ensuring that female finger assemblies on the Plug In unit mate properly with the male terminals on the feeder elements.

In the case of heavier Plug In units separate simple-to-use push-in/pull out tool is provided to physically ensure full mating between male terminals and female finger assemblies.

The Plug In unit is locked in position through spring loaded pins of the Plug In unit, mating with the corresponding holes on feeder element body, thus not necessities any bolting. The above sequence ensures that all required inter-locking are achieved and earth terminals mate before the phase terminals.

SALIENT FEATURES

Standardized Design of Feeder Elements, Joints and Tap-Off Provisions.

Feeder elements, with a **unique Single- Piece extruded Aluminium body**, with the conductors integrally spaced and mechanically stacked permanently by CAST- RESIN, ensures very high cross sectional rigidity with the least cross sectional area, achieving :-

- (a) High strength - to - weight ratio.
- (b) Absolute Ingress Protection to the level of IP 68
- (c) Easy to handle , during Transportation, Storage and Erection.

The fully earthed body (Continuity ensured through Positive earth connection at Joints) of the feeder elements including the covers of joints, ensure positively earthed exterior for full length of the Bus bar system, which is unique compared to any other solidly insulated design of Bus ways, and thus assures safety of personnel.

Unique joint Design, with more-than-usual contact area and higher Cross-section of fish plates, achieved through factory-made fishplates and Uniform contact pressure over the whole contact area, achieved through sufficiently sized externally assembled four nos each of steel clamps and steel bolts per Joint, ensure least joint resistance and hence least generation of heat. Joint tightness remains unaltered as the joint cavities are resin mix filled- and-sealed-for-life, after completion of due Erection Assembly and Testing, thereby avoiding the hassle of periodical checking of joint quality. High degree of Inter phase & phase to earth insulation achieved at the joints, by the use of high quality laminated phase Barriers of thickness 2mm, having a dielectric strength of more than 8kV/mm.

Current carrying efficiency of the conductors is not disturbed for the full length of the Busway system, as the conductors are used in as-extruded/ drawn condition, by Fully Avoiding Bending and Holes anywhere along the current carrying.

Optimum thermal performance, due mainly to the particular design combining Aluminium enclosing Solid, Void-Free, Resin Cast Insulation of conductors and through selection of optimum conductor cross-section, and uniform contact pressure over the entire available contact area.

High level of Insulation rated for 1000V-though actually capable of more than 8kV for 1 minute-through individual conductor insulation by sleeving to the level of minimum 5kV for 1 minute, additionally ensuring a physical separation between phases, Neutral and Earth Conductors, which is retained throughout the entire busway length, through properly selected Resin-Filler-Hardener combination for Insulation, which is mechanically and electrically strong, fire retardant and self extinguishing, with very stable electro-mechanical characteristics, in spite of temperature cycling or ageing, with required level of thermal conductivity.

Aligning and Jointing of two feeder elements is simplified by the use of factory made fish plate assemblies and a simple feeder element aligning tool. The use of this tool also ensures achieving uniform longitudinal gap between the feeder elements in a fool-proof manner.

Length Adjustment of Busway runs- In the event of this problem, due to a combination of variations, it can be easily adjusted at the nearest joint, by using extended fish plate assemblies and extended joint covers, thus eliminating the need for making special/ non-standard Feeder Elements. This is made possible, because of the independent double clamping of each joint, without causing any inferiorities in the Busway quality.

Easily installable Plug-in Tap-off Units- Rated from the lowest up to 1250A current Ratings, the tap-off Unit can be loaded on to the two side pins on the Feeder element, and manually plugged in and bolted onto Feeder Element, for ratings up to 250A, and for higher ratings , can be plugged-in by a simple tool, ensuring either way, the correct mating of current collecting male terminals on feeder element, and duly molded female finger assemblies in the Tap-Off Unit.

Standardised Tap-Off Provision, It is a unique feature with deltabar that the tapping -off provision on Feeder Elements, will be standardized to that required for the maximum rating assigned for any Tap Off Unit in a particular project. This gives the flexibility, for mounting Tap-Off Unit of any rating within the maximum rating, at any location, if it so demands, due to increased loads, during any point of time in the life of the Busway system.

TECHNOLOGY

DELATABAR is designed and manufactured to meet the stringent requirements of IEC 60439-1& 2 specifications, duly adaptable to applicable international and National standards, concerning current density, conductor cross-section, temperature rise limits, short-time with stand current, Ingress Protection, dielectric and Mechanical Strengths.

The design, method of manufacture and the constructional features, ensure the highest degree of Ingress Protection, to the level of IP 68, ensuring total protection through-out its life, at the same time making it totally protected against any fire hazards.

Physical separation, of the individually sleeved conductors within the duct and the high Quality Cast-Resin separation between them, increases many fold the dependability of the system and reduces or eliminates the chances of phase to phase or phase to earth short circuit, in the worst of situations.

This unique design of uniform Single- Piece Extruded Enclosure with internal solidly insulated conductors, makes **DELATABAR** the strongest and Sturdiest of designs evolved till date, for resisting the stringent Short Duration Fault Currents (Short Time Current), as already proven through type tests conducted and Certified by KEMA Quality, Netherlands, as per IEC 60439-1&2.

Faster dissipation of the heat, generated due to the operating temperature, is achieved through use of optimum conductor cross section, special solid Cast-Resin insulation between conductors and conductors to earth and the exclusively designed Aluminum Enclosure.

The temperature generated in the conductors is also proven to be well within allowable limits specified in IEC. (Refer Temperature-Rise Graph 1,2 & 3, evolved from values recorded during Temperature rise Type Tests.)

The Feeder Element with Tap-Off Provision is Proven for **IP68** Ingress Protection Rating. This makes '**DELATABAR**' the ideal choice for the most stringent of indoor or outdoor Application.

The Design of the Tap-Off Box is in such a way that, once the Tap-Off Unit is plugged in, the IP68 degree of the Feeder Element is retained intact.

The Design and Construction of the Tap-Off Unit in general and the Current collecting Rigid Male terminals and the flexible female finger Assemblies, are duly Proven through the Very Stringent Thermal Cycling Test of more than 20 days duration, involving, two successive sequences of current cycling of 3 hours On & OFF, each sequence consisting of 42 cycles, as per Clause 8.2.1.8 of the latest IEC 60439 – 2

DELATABAR is the only Brand of Busway System, which is subjected to and has successfully passed this Test and got Certified by KEMA Quality.

The length of Feeder Element is standardized to 3.5 metres, thereby reducing the no. of joints in a given length of the system, ensuring also that, Tap-off Units are within the specified height limit from floor level on all floors.

The standardised Design of **DELATABAR** offers many flexibilities and advantages. The whole Range from 800/1000A up to 3200A is accommodated in 2 Frame sizes, Frame size 1 of max overall size 140x200- upto 1600A and Frame Size 2 of Size 200x200, making it the most compact of Busways commercially available, however having the highest strength to weight or Strength to Cross-Section Ratio.

The design of Joints is also standardised with the Fish Plate Assemblies being same, for both Frame sizes and all Current Ratings, with the clamps and bolts having been standardized for all ratings of each Frame size.

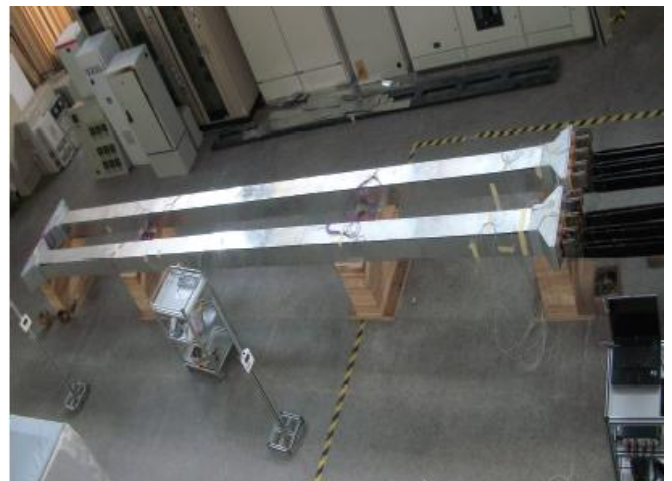

5000A Temperature Rise Test

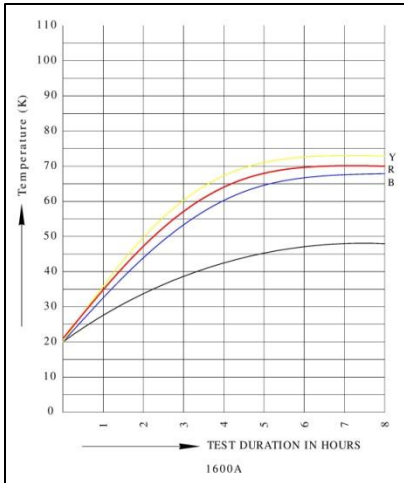

Graph-1

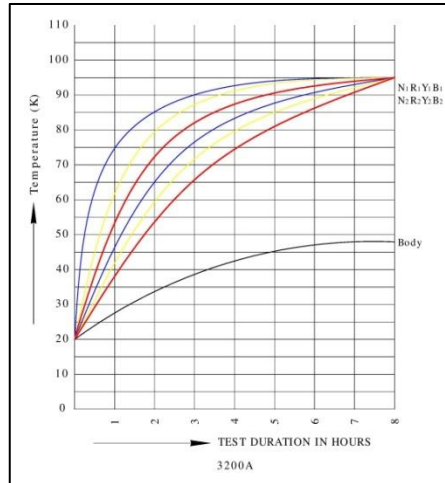

Graph-2

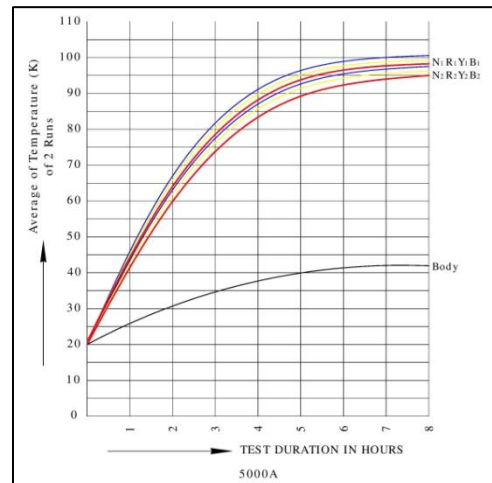

Graph-3

Manufacturing and Quality Assurance

DELTABAR Busways are manufactured in the modern state-of-the-art facilities.

The quality of the product is ensured through inspection of all incoming materials and at every major stage of processing and through hundred percent routine testing of the final product before despatch.

The normal routine tests on the final product are

- (i) Insulation resistance measurement and
- (ii) High Voltage Withstand tests

The standard busways are supplied with mill finish Aluminium body. However special aesthetic colouring by powder coating or anodizing can be offered, based on specific requirement.

Techno-Commercially

DELTABAR offers unique high-tech and high-quality product at comparably lowest cost burden for the customer.

Flexibility in part and/or progressive delivery, with the lowest delivery delay, is one of the very best advantages for the contractors and end users, in the subcontinent & GCC Countries.

WHY DELTABAR BUSWAY SYSTEMS?

Type Tested & Certified by KEMA Quality, Netherlands, for the full range 800/1000A to 3200A. Also available from 4000A to 9600A Range for Special Application of High Current Ratings, by using multiple Runs, of Required Certified Ratings, per Phase.

Comparatively of highest quality; sleek, compact and of light-weight; easy to handle and cost-effective.

High electrical insulation.

Full range of accessories - Flanges, Elbows, Offsets & T-elements, Expansion Joints, Reducer Elements, End Caps etc.

Easy & Fool-proof Installation through simple-to-use-at-site tooling.

Install - commission - and - maintenance free.

Factory-mixed joint-insulating Resin-Filler mix and accessories supplied as standard, for Joint filling at site.

TECHNICAL DATA SHEET (COPPER)

Rated Operational Voltage (Ue) = 1000V		Rated Insulation Level (Ui) = 1000V						Frequency (f) = 50 Hz						IP68						Tested & Certified by KEMA Quality , Netherlands					
		800	1000	1050	1250	1500	1600	1600	1600	2000	2500	2500	2500	3000	3200	4000	5000	6000	6400	7500	9000	9600			
1	Current Rating (A)	360	360	480	600	720	840	960	1200	1440	1680	1920	2880	3360	4320	5040	5760								
2	Cross Sectional Area per Phase (mm ²)	120x3	120x3	120x4	120x5	120x6	120x7	120x4x2	120x5x2	120x6x2	120x7x2	120x8x2	(120x4x2)2	(120x6x2)2	(120x7x2)2	(120x8x2)2	(120x8x2)3								
3	Conductor Size/Phase (mm)	2.22	2.78	2.19	2.25	2.08	2.22	2.08	2.08	1.74	1.79	1.67	2.08	1.74	1.79	1.67	1.67								
4	Current Density (A/mm ²)																								
5	Short Circuit Withstand (kA/1 Sec)	50						85						150											
6	Weight of Copper for N,R,Y,B & 50% E (Kg/m)	16	16	21	26	31	35	41	52	60	71	72	82	120	144	180	213	216							
7	Weight of Al.Encloser (Kg/m)	5.5 (Effective Cross Sectional Area 1922 Sq.mm)						8 (Effective Cross Sectional Area 2859 Sq.mm)						16 (E.C.S.Area 5718 Sq.mm)											
8	Weight of Busway (Kg/m)	38	38	41	46	50	56	74	85	93	101	109	148	186	218	288	303	327							
9	Overall Cross section - Uniform throughout including joints (mm)	125x185						185x185						2x(185x185)											
10	Frame Size	1						2						3											
11	Thermal Withstandability																								
12	Overload Capacity	185°C for 3 hours - Certified by KEMA Quality .																							
		More than 50% for 3 hours																							

TECHNICAL DATA SHEET (COPPER)

(as updated in November 2010)

Rated Operational Voltage (Ue) = 1000V		Rated Insulation Level (Ui) = 1000V										Frequency (f) = 60 Hz			IP68			Tested & Certified by KEMA Quality , Netherlands					
1	Current Rating (A)	750	950	1000	1250	1300	1400	1500	1900	2350	2850	3000	3800	4700	5700	6000	7050	9000					
2	Gross Sectional Area per Phase (mm ²)	360	360	480	600	720	720	840	960	1440	1680	1920	1920	2880	3360	3840	4320	5760					
3	Conductor Size/Phase (mm)	120x3	120x3	120x4	120x5	120x6	120x6	120x7	120x4x2	120x6x2	120x7x2	120x8x2	(120x4x2) ²	(120x6x2) ²	(120x7x2) ²	(120x8x2) ²	(120x6x2) ³	(120x8x2) ³					
4	Current Density (A/mm ²)	2.08	2.64	2.08	2.08	1.8	1.94	1.78	1.98	1.62	1.7	1.56	1.98	1.63	1.7	1.56	1.62	1.56					
5	Short Circuit Withstand Current (kA/1 Sec)	50		65						85			100			150			200				
6	Weight of Copper for N,R,Y,B & 50% E (Kg/m)	16	16	21	26	31	31	35	41	60	71	72	82	120	142	144	180	216					
7	Weight of Al. Encloser (Kg/m)	5.5 (Effective Cross Sectional Area 1922 Sq.mm)		8 (Effective Cross Sectional Area 2859 Sq.mm)						16 (E.C.S.-Area 5718 Sq.mm)			24 (E.C.S.-Area 8577 Sq.mm)										
8	Weight of Busway (Kg/m)	37	37	41	46	50	50	56	74	93	101	109	148	186	202	218	279	327					
9	Overall Cross section - Uniform throughout including joints (mm)	125x185		185x185						2x(185x185)			3x(185x185)										
10	Frame Size	1		2						2 Parallel Runs of Frame Size - 2 Elements			3 Parallel Runs of Frame Size - 2 Elements										
11	Thermal Withstandability	185°C for 3 hours - Certified by KEMA Quality .																					
12	Overload Capacity	More than 50% for 3 hours																					

TECHNICAL DATA SHEET (ALUMINIUM)

(as updated in February 2011)

Rated Operational Voltage (Ue) = 1000V		Rated Insulation Level (Ui) = 1000V										Frequency (f) = 60 Hz				IP68	
		800	900	1100	1250	1400	1600	1900	2200	2500	2800	3000	3200	3600	3850	4200	
1	Current Rating (A)	360	480	600	720	840	960	1200	1440	1680	1920	2160	2400	2880	3360	3840	
2	Cross Sectional Area per Phase (mm ²)	120x3	120x4	120x5	120x6	120x7	120x4x2	120x5x2	120x6x2	120x7x2	120x8x2	(120x4.5x2)2	(120x5x2)2	(120x6x2)2	(120x7x2)2	(120x8x2)2	
3	Conductor Size/Phase (mm)	2.22	1.88	1.83	1.75	1.7	1.67	1.6	1.53	1.48	1.46	1.39	1.33	1.25	1.15	1.09	
4	Current Density (A/mm ²)																
5	Short Circuit Withstand Current (kA/1 Sec)	50		65		85		100		150							
6	Weight of Copper for N,R,Y,B & 50% E (Kg/m)	4.6	5.9	7.5	8.8	10.4	11.7	14.58	17.4	20.4	23.3	26.2	29.1	34.9	40.8	46.6	
7	Weight of Al.Encloser (Kg/m)	5.5															
8	Effective Cross Sectional Area (Sq.mm)	1922															
9	Weight of Busway (Kg/m)	33	36	38	41	44	50	54	57	61	64	94	100	104	108	114	
10	Overall Cross section - Uniform throughout including joints (mm)	125x185															
11	Frame Size	1		185x185		2		2		2		2x(185x185)					
		2 Parallel Runs of Frame Size - 2 Elements															

VOLTAGE DROP VALUES FOR DIFFERENT CURRENT RATINGS

Voltage Drop Values in Volts/m for Different Current Ratings & Power Factor Values (TYPE TESTED VALUES)									
a. For Concentrated Load (Load Distribution Factor = 1 as per IEC)									
Rated Ampere	Conductor Size	Resistance at 20°C	Impedance (Z)	Resistance (R)	Reactance (X1)	Power Factor			
						0.9	0.85	0.8	0.75
A	mm	Ω/M	(μΩ/M)	(μΩ/M)	(μΩ/M)	Voltage Drop (Volts/m)			
1000	120x3x1	50	65	52	39	0.1105	0.1121	0.1126	0.1122
1050	120x4x1	37.5	51.5	44.7	25.7	0.0935	0.0937	0.0931	0.0919
1350	120x5x1	30	42.7	42.4	19.7	0.1093	0.1085	0.1069	0.1048
1400	120x6x1	25	41.2	40.1	16.7	0.1052	0.1040	0.1021	0.0997
1600	120x6x1	25	41.2	40.3	16.8	0.1208	0.1208	0.1173	0.1146
1600	120x7x1	21.4	36	38.6	14	0.1132	0.1114	0.1089	0.1059
2000	120x4x2	18.8	28.8	29.4	11	0.1083	0.0860	0.1043	0.1016
2500	120x5x2	15	23	21.6	21.2	0.1242	0.1279	0.1299	0.1309
2500	120x6x2	12.5	23	17.3	19	0.1032	0.1108	0.1093	0.1106
3000	120x7x2	10.7	19.2	14.1	18	0.1067	0.1115	0.1147	0.1168
3200	120x8x2	9.4	18	14.4	20.7	0.1218	0.1283	0.1327	0.1357
b. For Distributed Load (Load Distribution Factor is assumed as .05)									
Rated Ampere	Conductor Size	Resistance at 20°C	Impedance (Z)	Resistance (R)	Reactance (X1)	Power Factor			
						0.9	0.85	0.8	0.75
A	mm	Ω/M	(μΩ/M)	(μΩ/M)	(μΩ/M)	Voltage Drop (Volts/m)			
1000	120x3x1	50	65	52	39	0.0553	0.0561	0.0563	0.0561
1050	120x4x1	37.5	51.5	44.7	25.7	0.0468	0.0469	0.0465	0.0459
1350	120x5x1	30	42.7	42.4	19.7	0.0547	0.0543	0.0535	0.0524
1400	120x6x1	25	41.2	40.1	16.7	0.0526	0.0520	0.0510	0.0499
1600	120x6x1	25	41.2	40.3	16.8	0.0604	0.0604	0.0586	0.0573
1600	120x7x1	21.4	36	38.6	14	0.1132	0.0557	0.0544	0.0529
2000	120x4x2	18.8	28.8	29.4	11	0.0541	0.0430	0.0522	0.0508
2500	120x5x2	15	23	21.6	21.2	0.0621	0.0639	0.0650	0.0654
2500	120x6x2	12.5	23	17.3	19	0.0516	0.0554	0.0546	0.0553
3000	120x7x2	10.7	19.2	14.1	18	0.0534	0.0558	0.0574	0.0584
3200	120x8x2	9.4	18	14.4	20.7	0.0609	0.0641	0.0663	0.0679

2. Voltage Drop Values in Volts/m for Different Current Ratings & Power Factor Values (TYPE TESTED VALUES)

a. For Concentrated Load (Load Distribution Factor = 1 as per IEC)

Rated Ampere	Conductor Size	Resistance at 20°C	Impedance (Z)	Resistance (R) at 80°C	Reactance (X1) at 80°C	Power Factor			
						0.9	0.85	0.8	0.75
A	mm	Ω/M	(μΩ/M)	(μΩ/M)	(μΩ/M)	Voltage Drop (Volts/m)			
1000	120x3x1	50	65	37	38	0.0864	0.0891	0.0908	0.0916
1050	120x4x1	37.5	51.5	35	24	0.0763	0.0771	0.0771	0.0766
1350	120x5x1	30	42.7	38	19.4	0.0997	0.0994	0.0983	0.0966
1400	120x6x1	25	41.2	30.2	28	0.0955	0.0980	0.0993	0.0998
1600	120x6x1	25	41.2	30.2	19.8	0.0992	0.0992	0.0999	0.0991
1600	120x7x1	21.4	36	26.4	23	0.0936	0.0958	0.0968	0.0970
2000	120x4x2	18.8	28.8	23.2	17.5	0.0988	0.0939	0.1007	0.1004
2500	120x5x2	15	23	18.5	13.6	0.0978	0.0991	0.0994	0.0990
2500	120x6x2	12.5	23	15.4	17	0.0920	0.0988	0.0975	0.0987
3000	120x7x2	10.7	19.2	13.2	13.9	0.0932	0.0963	0.0982	0.0992
3200	120x8x2	9.4	18	11.6	13.7	0.0910	0.0946	0.0970	0.0984

b. For Distributed Load (Load Distribution Factor is assumed as .05)

Rated Ampere	Conductor Size	Resistance at 20°C	Impedance (Z)	Resistance (R) at 80°C	Reactance (X1) at 80°C	Power Factor			
						0.9	0.85	0.8	0.75
A	mm	Ω/M	(μΩ/M)	(μΩ/M)	(μΩ/M)	Voltage Drop (Volts/m)			
1000	120x3x1	50	65	37	38	0.0432	0.0446	0.0454	0.0458
1050	120x4x1	37.5	51.5	35	24	0.0382	0.0385	0.0386	0.0383
1350	120x5x1	30	42.7	38	19.4	0.0499	0.0497	0.0491	0.0483
1400	120x6x1	25	41.2	30.2	28	0.0478	0.0490	0.0497	0.0499
1600	120x6x1	25	41.2	30.2	19.8	0.0496	0.0496	0.0499	0.0495
1600	120x7x1	21.4	36	26.4	23	0.0936	0.0479	0.0484	0.0485
2000	120x4x2	18.8	28.8	23.2	17.5	0.0494	0.0469	0.0503	0.0502
2500	120x5x2	15	23	18.5	13.6	0.0489	0.0496	0.0497	0.0495
2500	120x6x2	12.5	23	15.4	17	0.0460	0.0494	0.0488	0.0493
3000	120x7x2	10.7	19.2	13.2	13.9	0.0466	0.0482	0.0491	0.0496
3200	120x8x2	9.4	18	11.6	13.7	0.0455	0.0473	0.0485	0.0492

Reference:

(i) Voltage Drop Formula according to IEC 60439 - 2 – Page No: 49, Annex: J

(ii) **Voltage Drop in Volts, $u = k \times \sqrt{3} \times (R_1 \cos \phi + X_1 \sin \phi) \times I_b \times L$, in Volts** - as per 3. a.(i)

Where K = Load Distribution Factor

I_b = Current of the circuit being considered (A)

R = Mean Resistance of the system (Ω/meter)

X = Mean Reactance of the system (Ω/meter)

L = Length of the system being considered (m.)

$\cos \phi$ = Load Power Factor

The Load Distribution Factor could be suitably selected from any of the 3 values below

a. $K = 1$ - if the load is concentrated at the end of the busbar trunking run.

b. $K = \frac{n+1}{2n}$ - if the load is uniformly spread between n branches

c. $K = \frac{2n+1}{2} \times \frac{d}{L}$ - When loads are spread uniformly along the length of the busbar trunking run.

$$\frac{L}{2 \times n}$$

Where n is the number of tap offs; d is the distance between the tap off and origin of the busbar and L is the length of the busbar trunking run.

Straight Length Feeder

The feeder elements are of standardized design of 3.5m maximum length(shorter lengths are designed based on requirement), with the whole range up to 3200A being covered in two frame sizes - decided by two standardized enclosures one accommodating upto1600A with single conductor per phase(Frame size-1) and the other up to 3200A with two conductors per phase(Frame size-2), the width of the conductor standardized to 120mm in both frame sizes, their thickness varying from 3 to 7mm to cater to different current ratings.

For ratings above 3200A and up to 6400A, DELTABAR design envisages use of two parallel runs of elements of frame size 2.

Each bend-free phase and neutral conductor is individually color-sleeved using special, thermally & dielectrically high quality heat shrinkable sleeves and the conductors are spaced apart at a uniform gap of 10mm between the conductors

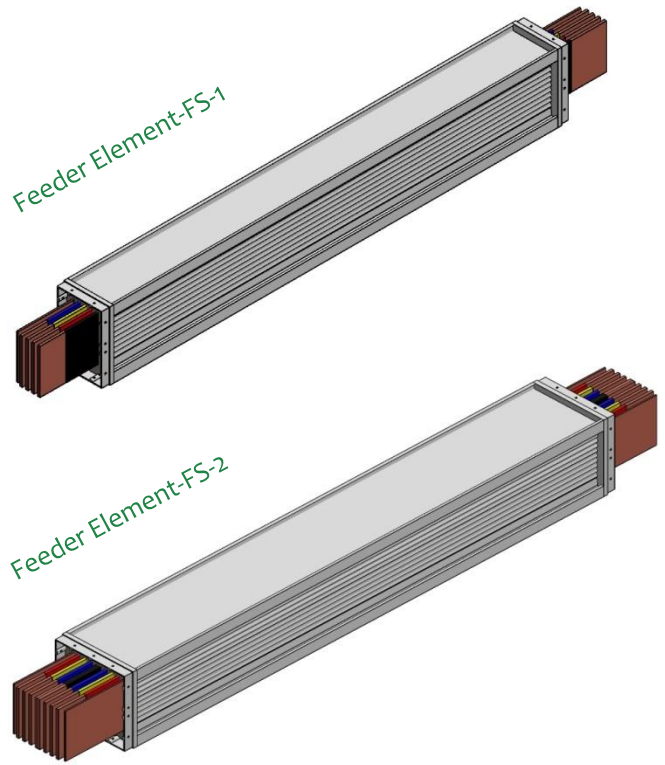

Cross-Sectional View

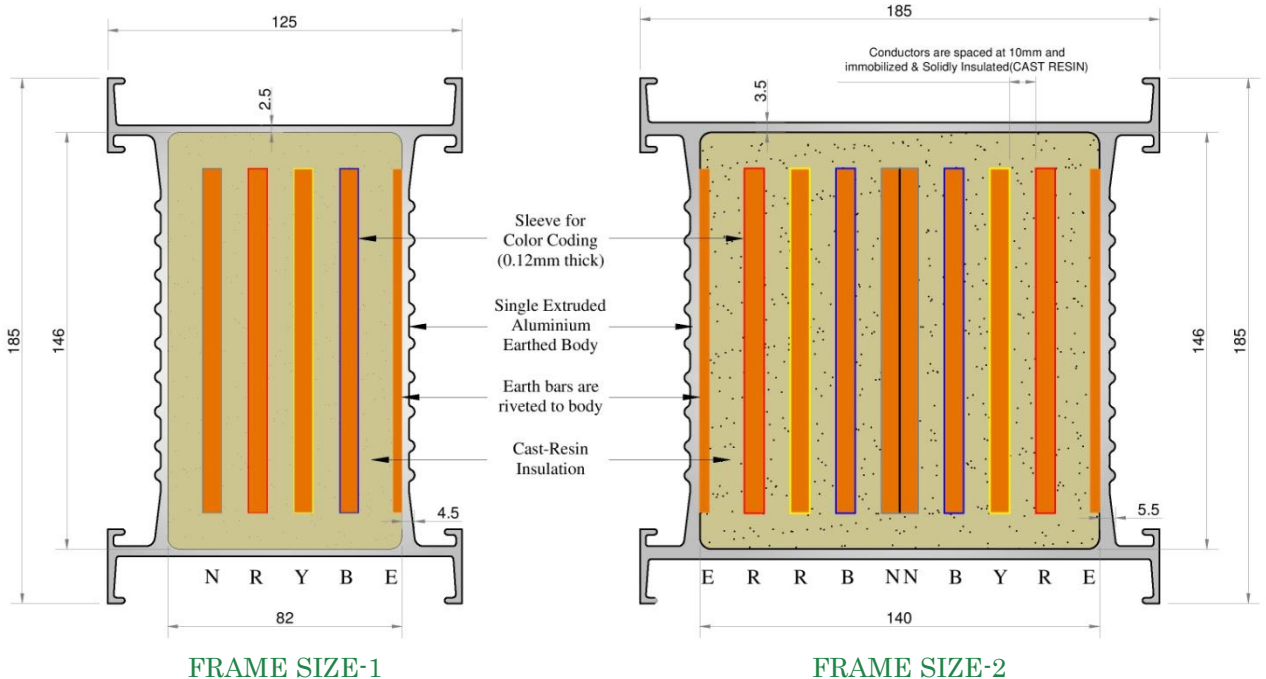

Elbows

Elbows are standardized to dimensions of 482x482mm and are available in flat-wise & edge-wise types. Constructionally they are typical to feeder elements with projecting out conductors, suitable for standard joint connections.

Unless unavoidable, flat wise elbows are not recommended, as they reduce the current-carrying efficiency of the system, due to 90o bending of the conductors, which results in broken conductor molecules.

Typical Combination elbows - Offsets, Combination & Obtuse elements are designed, where critical site conditions does not allow connection of standard elbows. Also depending on project requirement, elbow joints can also be provided to cater to very short length elbow.

Flat-wise Elbow

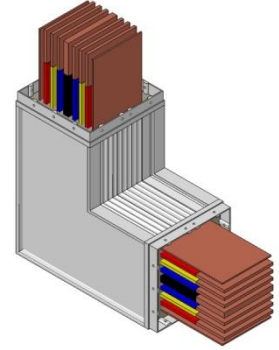

Edge-wise Elbow

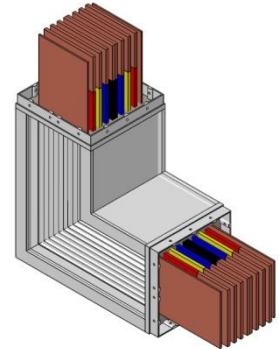

Flat-wise Offset Elbow

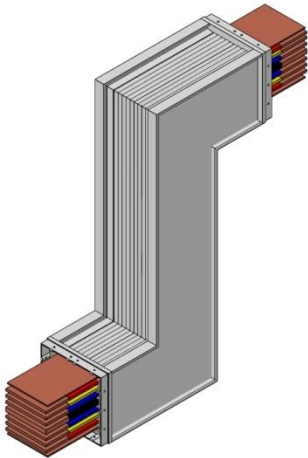

Edge-wise Offset Elbow

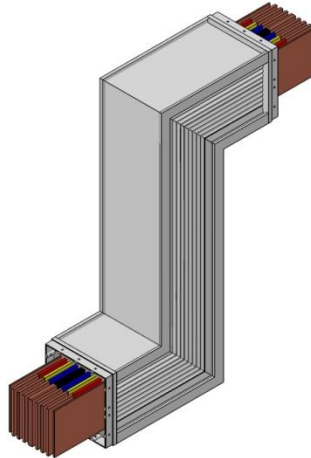

Combination Elbow

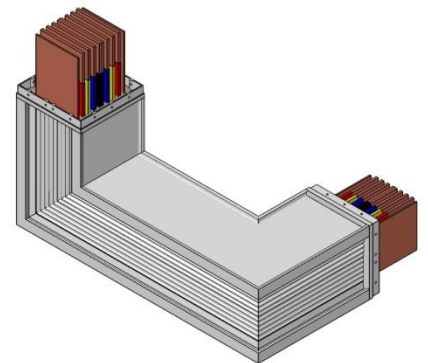

Flat-wise Obtuse Elbow

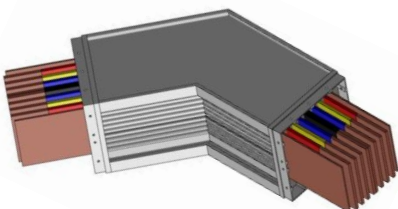

Edge-wise Obtuse Elbow

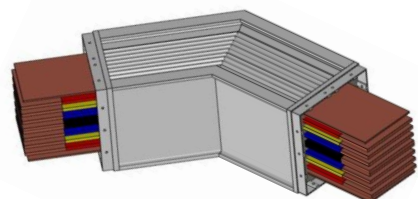

Flanges

DELTABAR flanges are compact, with sealable metallic mounting body & hidden mounting provisions. The terminating conductor elements are tin-plated & holed for connection to switchgear termination.

Flange - Frame Size-1

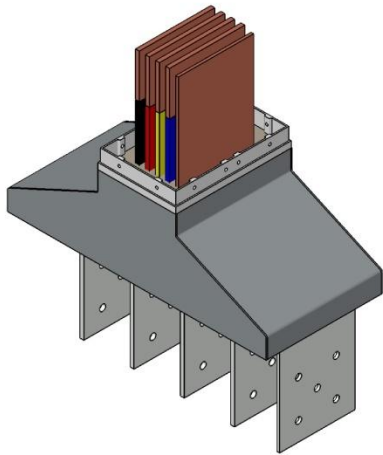

Edge-wise Elbow Flange

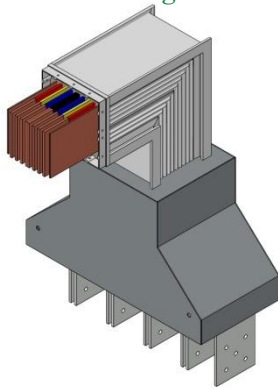

Flange - Frame Size-2

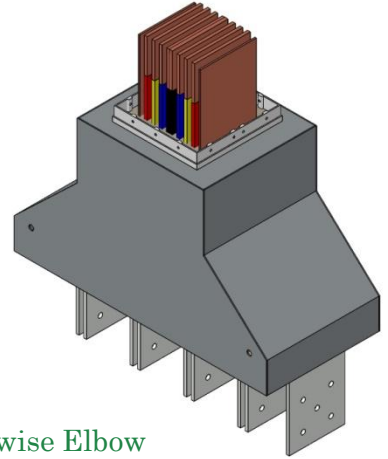

Flat-wise Elbow Flange

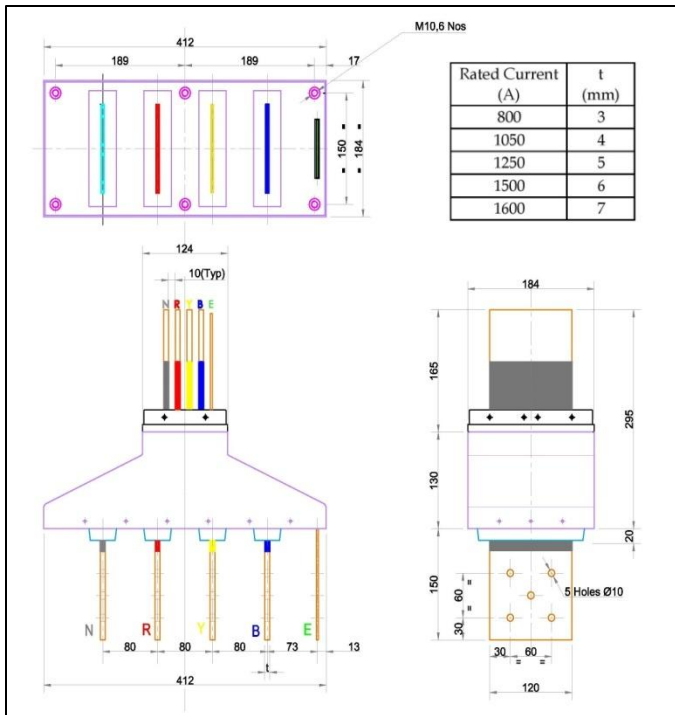
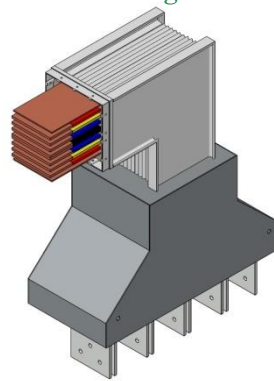

Flange For Frame Size-1
(up to 1600A –Single Conductor /Phase)

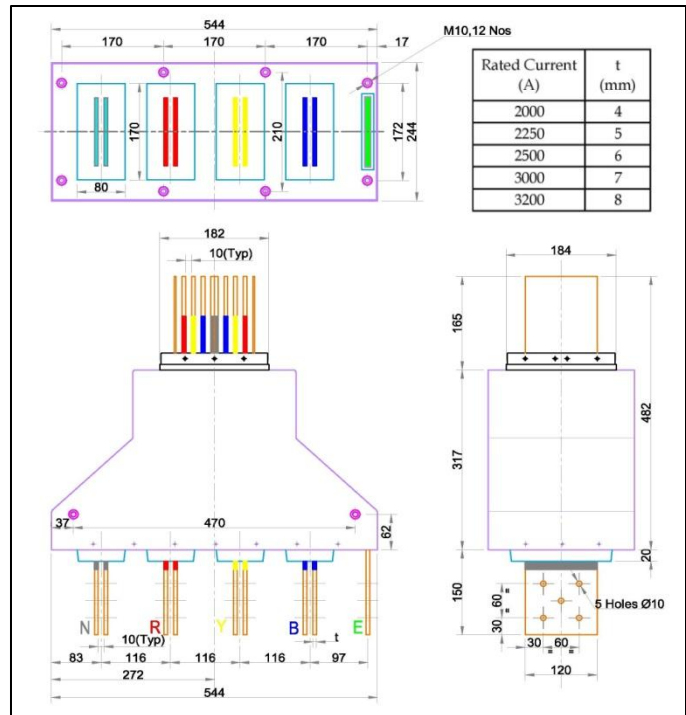

Flange For Frame Size-2
(Double Conductor /Phase)

Joints

Any joint in an electric conductor is the weakest point, as far as the efficiency of current carrying is concerned, decided by the level and uniformity of contact pressure, the extent of the contact area, the joint resistance and ultimately the conductivity and thermal performance, and hence is given the maximum technical considerations in its design, in **DELTABAR**.

- DELTABAR** joint are uniquely design with :-
- Two numbers straight fish-plates, one on either side of each phase and neutral conductor
 - The fish plates having more cross sectional area than that of the conductor
 - More than usual overlap of fish plates with conductors
 - Phase segregation by high quality molded phase barriers
 - 4 clamps, 4bolts steel clamping (external bolting). This ensures a thermally, electrically and mechanically proper and efficient joint design. The joints are covered by aluminium covers and the left over annular space are filled up by the same resin cast mix used in the feeder elements, thus making it life-time-maintenance free.

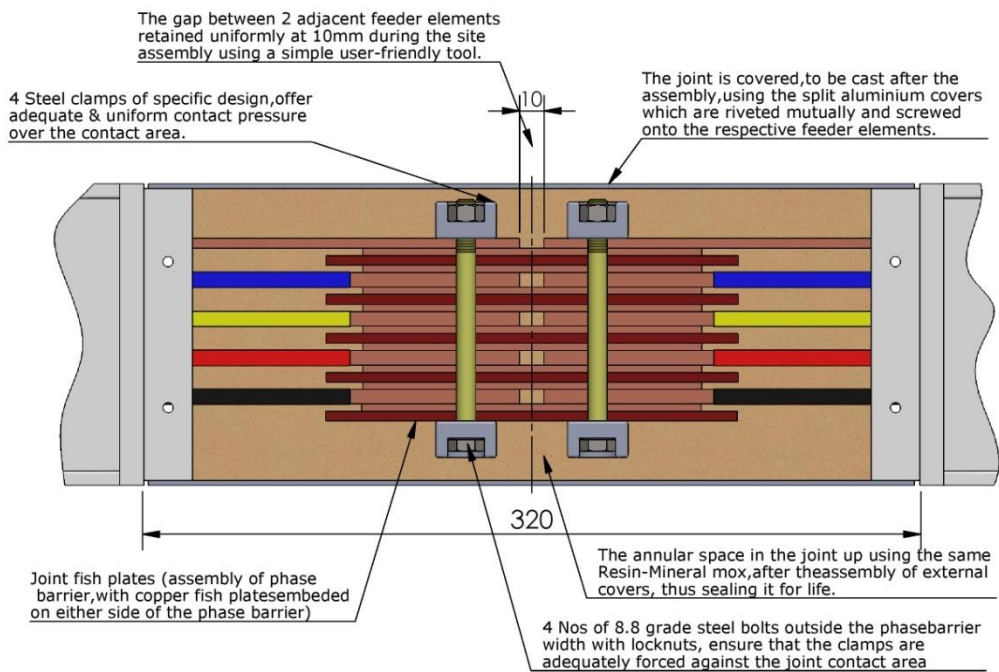
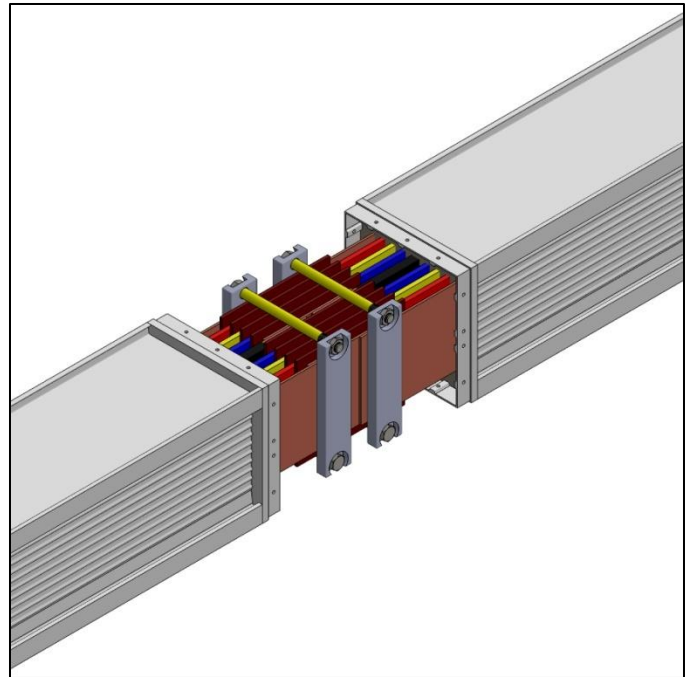

Typical Joint Assembly of Frame Size-1 Feeder Element

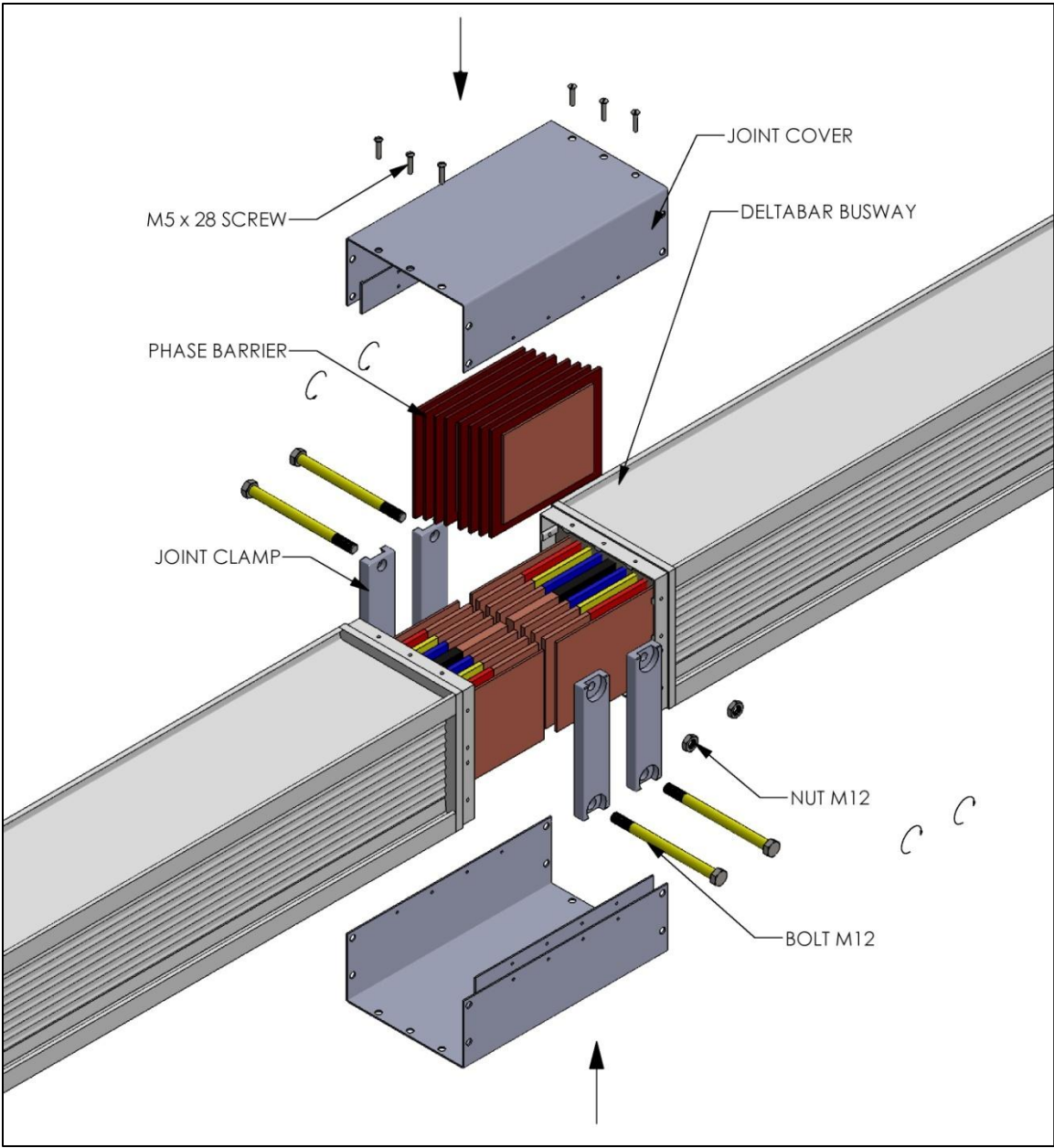

Joint Assembling Process Overview

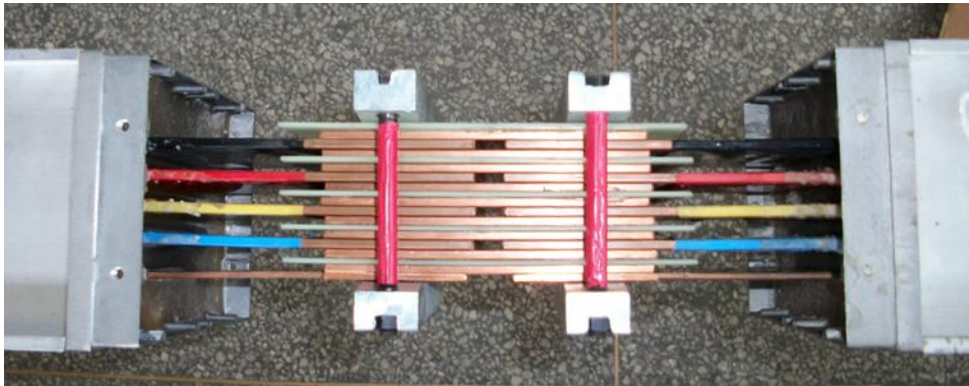

Supports

Spring supports specially designed to support the weight of busways on each floor shall be provided as shown, for supporting vertical runs. The spring support assemblies are standardised for each Frame Size, accounting the largest weight of elements in each Frame Size.

For horizontal applications, the busways are supported by threaded rods and hanger channels, where so preferred by our customers. The Standard arrangement of **DELTABAR** for horizontal runs, how ever in rigid Steel Frame Supports screwed on to Roof slab bottom.

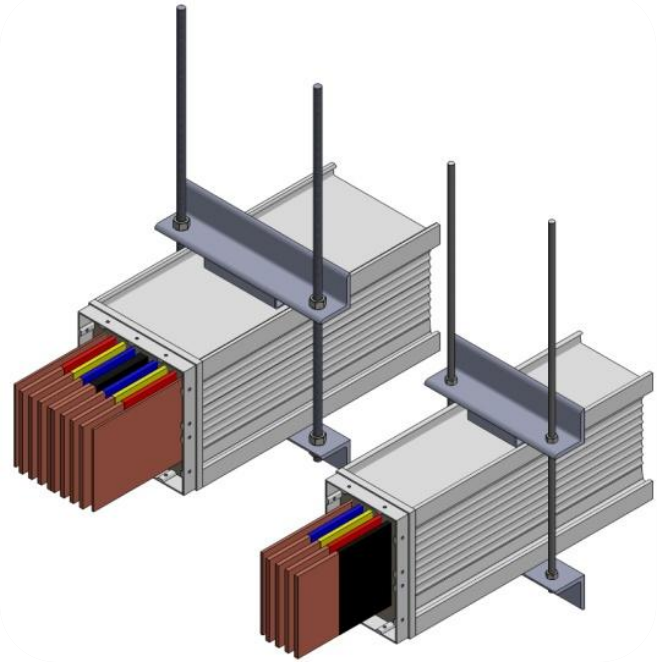

Rigid Support For Horizontal Runs

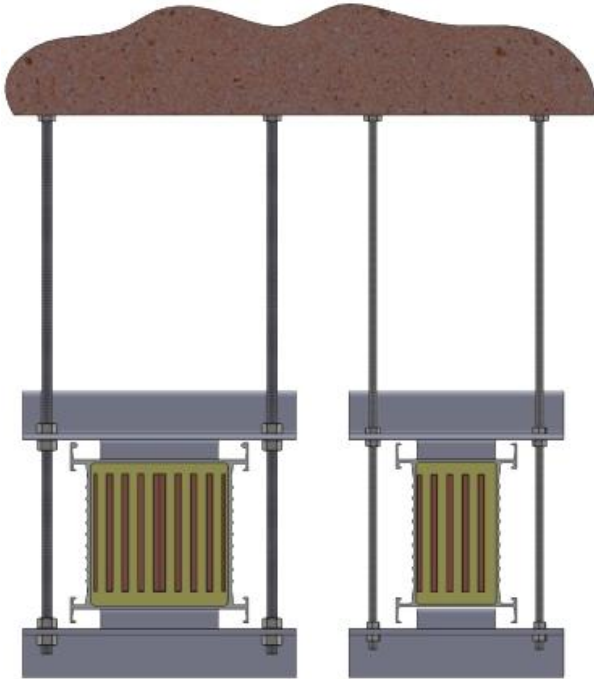

Spring Support For Vertical Runs

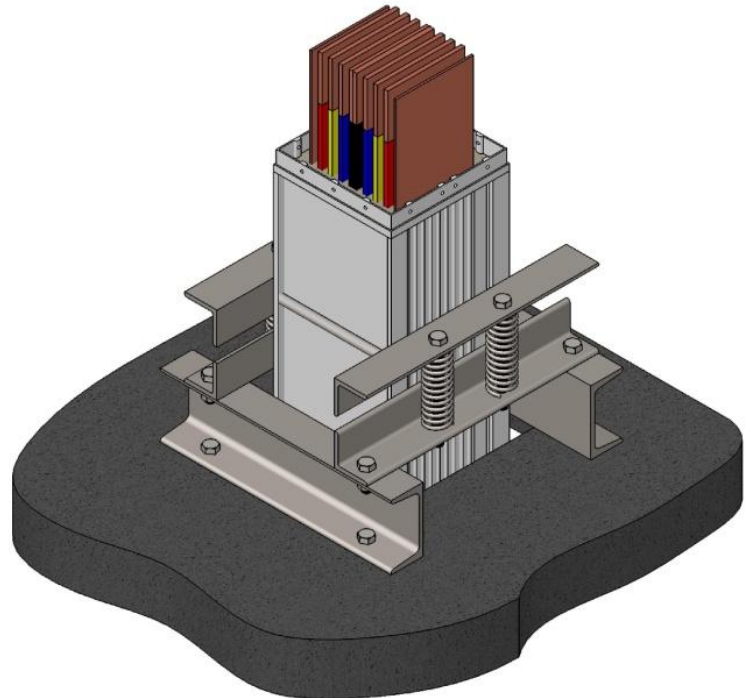

Expansion Joint

Depending on load condition and the external environment, the conductors may have a tendency to contract/expand (Thermal expansion). Specially designed expansion joints are provided to suppress those effects.

Expansion joints are recommended on every 40 m runs of straight conductor and also when the busway crosses the building expansion joints. These joints are normally designed for +/-30mm length. Special designs are also available for up to +/-90mm.

Transverse Joint

Transverse Joints/Building Cross-over elements are provided, where the Busway crosses a building joint. The element will allow flexibility to the Busway Systems otherwise rigid & non-flexible Cast-Resin Busway, to accommodate the Non-uniform Building oscillation due to wind load. To ensure that the Transverse Element functions effectively, it shall be ensured that the Feeder Element crosses the Building only in a way that its conductor are oriented Vertically inside.

Expansion Joint

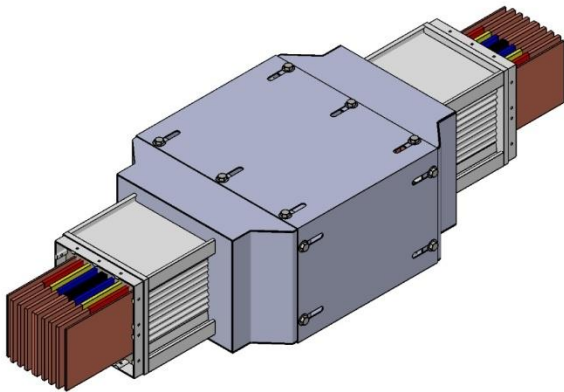

Transverse Joint

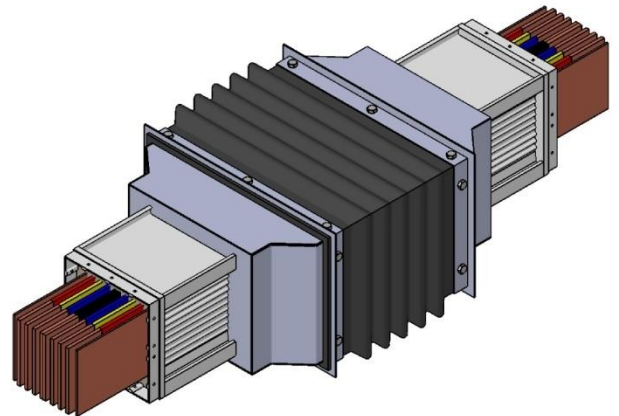

Compact Expansion Joint

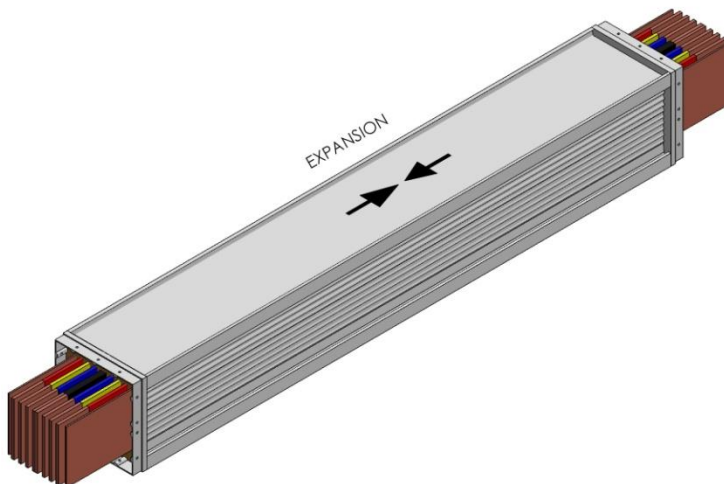

Plug-In Units

Unlike in the case of Power Distribution of cables, wherein, multiple cables run from the power source (incoming) to each load point or load centre, busway systems transfer power from the source (normally the LV panel /Main distribution board) up to the last load point, with provision for tapping off power at the various load points along its way, through tap-off units and passes it on to the Sub-Main distribution boards of domestic, industrial or other load groups.

Though each busway design, make or manufacturer evolves their own design of tap off units (both Bolted or Plug-in), plug-in Tap Off units are considered to be most ideal, as these can be plugged out for repair, when & if necessitated, even when the busway is live, retaining power without disturbing other load points. **DELTABAR** has evolved unique tap-off units, with standardized design & frame size, thereby ensuring utmost reliability and efficiency in power collection, irrespective of the magnitude of the current rating.

- i. The current carrying (collecting) parts on the tap off units are accommodated in a cast-resin tap-off moulding of two frame sizes, one to suit the Frame Size-1 feeder elements(5-bar) and the other for Frame Size- 2 elements(10-bar)
- ii. The female finger units of standardized design, one set catering up to 100/250A and using multiples of the same as required for higher current ratings - 2 sets\per phase up to 500A; 3 sets per phase up to 630A; 4 sets per phase up to 800A and 6 sets per phase up to 1250A.
- iii. This is made possible by standardizing the thickness of the mating male terminal thickness to 6mm, irrespective of the thickness of the main conductors of the feeder elements, of Frame Size-1 or Frame Size-2.

Easiest method of hooking at the top, pushing-into-position and locking bottom by spring loaded pins is adopted for simplifying the mounting of even the 1250A rated heavier Tap-off Units.

The Plug in units are designed such that earth mates first and breaks last ensuring safety. The feeder element with tap-off provisions are proven by type tests for IP68 protection rating, & the tap-off units are IP66 rated.

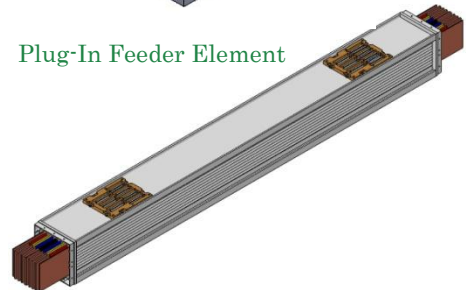
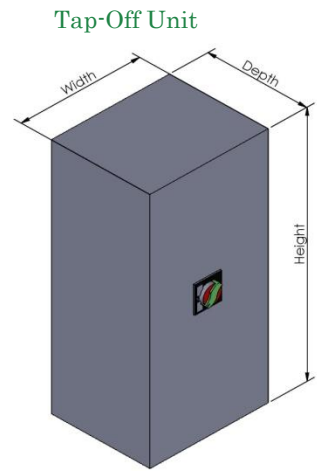
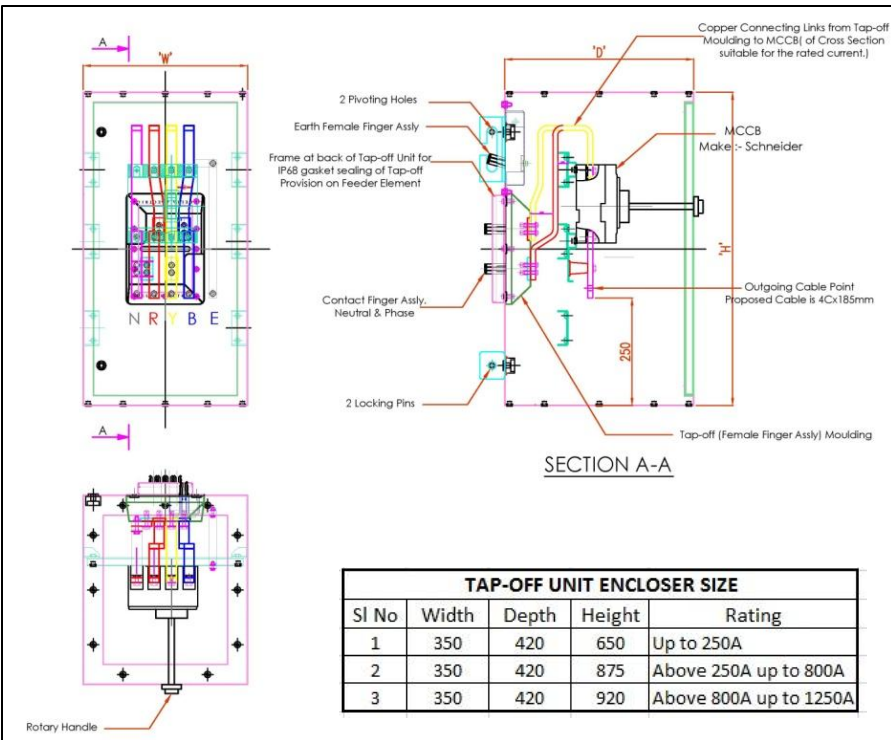

Tap-Off Unit Construction Details

DELTABAR – Design Validation

The Design Validation of the entire Range of **DELTABAR** Busways i.e, 800A up to 3200A in Standard Configuration, and up to 5000 A in double run arrangement, has been completed though successful Type Tests & Certification by KEMA Quality, Netherlands, as per clause 8.2 of IEC 60439-1 & 2 and **DELTA ELECTRIC** specification(for Thermal Withstandability) and by CPRI, India for circuit integrity test as per IEC 60331 & 3

**List of Type Test Conducted as per
IEC 60439-1 & 2 & Delta Electric Specification**

SI No	Sub-Clause of IEC	Type Test Description
1.	8.2.1.3a	Temperature Rise of Busways.
2.	8.2.1.3b	Temperature Rise of Busways With Tap-off Units.
3.	8.2.2	Di-electric Properties.
4.	8.2.3.lcw	Short-Time Current Test of Busways.
5.	8.2.3.lcc	Short-Time Current Test of Busways With Tap-off Units.
6.	8.2.4.	Effectiveness of protective circuit of Busways.
7.	8.2.4.	Effectiveness of protective circuit of Busways with Tap-off Units.
8.	8.2.5.	Clearance and Creepage Distances.
9.	8.2.6.	Mechanical operation of plugging-in-and-out of Tap-Off-Units.
10.	8.2.7.	Degree of protection of Busways with Tap-off provision - IP 68.
11.	8.2.7.	Degree of protection of Tap-off Units - IP 66.
12.	8.2.9.	Resistance of insulating materials to Abnormal Heat & Fire.
13.	8.2.10.	Structural Strength.
14.	8.2.12.	Crushing Resistance.
15.	8.2.13.	Electrical Characteristics.
16.	8.2.14.	Resistance to flame propagation.
17.	8.2.15.	Fire Resistance in Building Penetration. (Tested at Vertical position)
18.	8.2.1.3b(spl)	Thermal Cycling Test of Tap-off Unit.
19.	Delta Electric Specification	Special Test as per Delta Electric Specification, to assess the THERMAL With-standability of the Cast-Resin Insulating Material, by subjecting the Conductors of the Feeder Element to minimum 185°C for 3 hours in line with IEC 85 & UL 1446.
20.	IEC 60331-3	Test for Electric Cables under Fire Condition-Circuit Integrity (with Conductors Energised)

ATTESTATION OF CONFORMITY

No. 3301248.01A

Issued to: DELTA ELECTRIC
P. O. Box No. 121 080
SHARJAH
UNITED ARAB EMIRATES (U.A.E)

For the product: low-voltage busbar trunking system (copper bar)

Trade name: DELTABAR

Type/Model: Copper busbar trunking system with and without tap off unit outlet
DELTABAR 1000/2000

Copper busbar trunking system without tap off unit outlet
DELTABAR 1050/1350/1400/1500/1600/2500/3000/3200

Ratings: See annex

Manufactured by: DELTA ELECTRIC
P. O. Box No. 121 080
SHARJAH
UNITED ARAB EMIRATES (U.A.E)

Subject: Type tests

Requirements: IEC 60439-2, 3rd ed. 2000-03 and Amendment 1 2005-08
Clauses: 8.2.1, 8.2.2, 8.2.3, 8.2.4, 8.2.5, 8.2.6, 8.2.7, 8.2.9, 8.2.10, 8.2.12, 8.2.13, 8.2.14 and 8.2.15

Remarks: Clauses 8.2.8 and 8.2.11 are not applicable for this type of product

This Test Certificate is granted on account of an examination by KEMA Quality, the results of which are laid down in confidential report nos. 3301248.01 up to 3301248.10, dated July 15, 2010.

The examination has been carried out on one single specimen of the product, submitted by the manufacturer. The Attestation does not include an assessment of the manufacturer's production. Conformity of his production with the specimen tested by KEMA Quality is not the responsibility of KEMA Quality

KEMA Quality B.V.
Arnhem, July 15, 2010

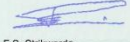

F.S. Strikwerda
Certification Manager

© Integral publication of this certificate and adjoining reports is allowed

KEMA Quality B.V. Urechtsweg 310, 6812 AR Arnhem P.O. Box 5185, 6802 ED Arnhem, The Netherlands
T +31 26 356 2000 F +31 26 352 5800 www.kemaquality.com Company registration 06085396

a **DEKRA** company

ATTESTATION OF CONFORMITY

No.: 3301248.14A

Issued to: DELTA ELECTRIC
P. O. Box No. 121 080
SHARJAH
UNITED ARAB EMIRATES (U.A.E)

Product: low-voltage busbar trunking system (copper bar)

Trade name(s): DELTABAR

Type(s)/model(s): DELTABAR 5000, copper busbar trunking system without tap off unit outlet
2 of DELTABAR 2500 used in parallel

Ratings: See annex

Manufactured by: DELTA ELECTRIC
P. O. Box No. 121 080
SHARJAH
UNITED ARAB EMIRATES (U.A.E)

Subject: Tests of Clauses: 8.2.1, 8.2.2, 8.2.3, 8.2.4, 8.2.5, 8.2.7, 8.2.9, 8.2.10, 8.2.12, 8.2.14 and 8.2.15

Requirements: IEC 60439-2, 3rd ed. 2000-03 and Amendment A1 2005-08

This Attestation is granted on account of an examination by KEMA Quality, the results of which are laid down in a test report No. 3301248.14, dated July 15, 2010.

The examination has been carried out on one single specimen of the product, submitted by the manufacturer. The Attestation does not include an assessment of the manufacturer's production. Conformity of his production with the specimen tested by KEMA Quality is not the responsibility of KEMA Quality.

Arnhem, July 15, 2010

KEMA Quality B.V.



F.S. Strikwerda
Certification Manager

KEMA Quality B.V. Urechtsweg 310, 6812 AR Arnhem P.O. Box 5185, 6802 ED Arnhem, The Netherlands
T +31 26 356 2000 F +31 26 352 5800 www.kemaquality.com Company registration 09085396

a **DEKRA** company

ANNEX TO ATTESTATION OF CONFORMITY No. 33012481.01A Page 1 of 2

- Rating**
- Busbar trunking systems**
- Trade name : DELTABAR
- Type : Copper busbar trunking system with/without tap off outlet
DELTABAR 1000/2000
- Copper busbar trunking system without tap off unit outlet
DELTABAR 1050/1350/1400/1500/1600/2500/3000/3200
- Tap off unit
250 A, 630 A
- Tested ratings for busbar trunking systems**
- Rated insulation voltage (Ui) : 1000 V
Rated impulse voltage (Uimp) : 8 kV
Rated frequency : see table on the next page
Rated operational voltage (Ue) : 1000 V
Degree of protection : IP 68
Rated operational current (Ie) : see table on the next page
Short-circuit withstand strength of assembly (Icw) : see table on the next page
Bus bar dimensions : see table on the next page
Resistance to flame propagation : Yes
Fire resistance in building penetrations : 60 minutes
Tested ratings for tap off unit
- Rated insulation voltage (Ui) : 690 V
Rated impulse voltage (Uimp) : 8 kV
Rated frequency : 50 Hz
Rated operational voltage (Ue) : 415 V
Degree of protection : IP 20
Rated operational current (Ie) : 250 A, 630 A
Rated conditional short-circuit current (Icc) : 20 kA at 415 V

ANNEX TO ATTESTATION OF CONFORMITY No. 33012481.01A Page 2 of 2

Short-circuit ratings

Busbar trunking systems:

Type	Ie		Icw 3-phase	Icw N and PE	Material
	50 Hz	60 Hz			
DELTABAR 1000	1000 A	950 A	65 kA / 1 s	30 kA / 1 s	Copper
DELTABAR 1050	1050 A	1000 A			
DELTABAR 1350	1350 A	1250 A			
DELTABAR 1400	1400 A	1300 A			
DELTABAR 1500	1500 A	1400 A	85 kA / 1 s	51 kA / 1 s	
DELTABAR 1600	1600 A	1500 A			
DELTABAR 2000	2000 A	1900 A	100 kA / 1 s	80 kA / 1s	
DELTABAR 2500	2500 A	2350 A			
DELTABAR 3000	3000 A	2850 A			
DELTABAR 3200	3200 A	3000 A			

Bus bar dimensions

Type	Ie		Phase bar and N bar size	PE bar size
	50 Hz	60 Hz		
DELTABAR 1000	1000 A	950 A	(120 x 3) mm ² x 1	(80 x 3) mm ² x 1
			(120 x 4) mm ² x 1	(80 x 3) mm ² x 1
			(120 x 5) mm ² x 1	(120 x 3) mm ² x 1
DELTABAR 1050	1050 A	1000 A	(120 x 4) mm ² x 1	(80 x 3) mm ² x 1
			(120 x 5) mm ² x 1	(120 x 3) mm ² x 1
			(120 x 6) mm ² x 1	(120 x 3) mm ² x 1
DELTABAR 1350	1350 A	1250 A	(120 x 6) mm ² x 1	(120 x 3) mm ² x 1
			(120 x 6) mm ² x 1	(120 x 3) mm ² x 1
			(120 x 6) mm ² x 1	(120 x 3) mm ² x 1
DELTABAR 1400	1400 A	1300 A	(120 x 6) mm ² x 1	(120 x 3) mm ² x 1
			(120 x 6) mm ² x 1	(120 x 3) mm ² x 1
			(120 x 6) mm ² x 1	(120 x 3) mm ² x 1
DELTABAR 1600	1600 A	1500 A	(120 x 6) mm ² x 1	(120 x 3) mm ² x 1
			(120 x 7) mm ² x 1	(120 x 4) mm ² x 1
			(120 x 7) mm ² x 1	(120 x 4) mm ² x 2
DELTABAR 2000	2000 A	1900 A	(120 x 4) mm ² x 2	(80 x 3) mm ² x 2
			(120 x 5) mm ² x 2	(120 x 3) mm ² x 2
			(120 x 6) mm ² x 2	(120 x 3) mm ² x 2
DELTABAR 2500	2500 A	2350 A	(120 x 6) mm ² x 2	(120 x 3) mm ² x 2
			(120 x 7) mm ² x 2	(120 x 4) mm ² x 2
			(120 x 7) mm ² x 2	(120 x 4) mm ² x 2
DELTABAR 3000	3000 A	2850 A	(120 x 7) mm ² x 2	(120 x 4) mm ² x 2
			(120 x 8) mm ² x 2	Enclosure is used as PE
			(120 x 8) mm ² x 2	

KEMA Quality

TEST CERTIFICATE

No. 3301248.100

Issued to: DELTA ELECTRIC
P. O. Box No. 121 080
SHARJAH
UNITED ARAB EMIRATES (U.A.E)

For the product: low-voltage busbar trunking system (copper bar)

Trade name: DELTABAR

Type/Model: DELTABAR 1000
Copper busbar trunking system with and without tap off unit outlet

Ratings: Busbar: Ue 1000 V, Ui 1000 V, Uimp 8 kV, In 1000 A at 50 Hz /
950 A at 60 Hz, low 50 kA – 1.0 s
Tap-off unit: Ue 415 V, Ui 690 V, Uimp 8 kV, In 250 A, Icc 20 kA at 415 V

Manufactured by: DELTA ELECTRIC
P. O. Box No. 121 080
SHARJAH
UNITED ARAB EMIRATES (U.A.E)

Subject: Type tests

Requirements: IEC 60439-2, 3rd ed. 2000-03 and Amendment A1 2005-08
Clauses: 8.2.1, 8.2.2, 8.2.3, 8.2.4, 8.2.5, 8.2.6, 8.2.7, 8.2.9, 8.2.10, 8.2.12,
8.2.13, 8.2.14 and 8.2.15

Remarks: Clauses 8.2.8 and 8.2.11 are not applicable for this type of product

This Test Certificate is granted on account of an examination by KEMA Quality, the results of which are laid down in report no. 3301248.01, dated July 15, 2010.

The examination has been carried out on one single specimen of the product, submitted by the manufacturer. The Attestation does not include an assessment of the manufacturer's production. Conformity of his production with the specimen tested by KEMA Quality is not the responsibility of KEMA Quality

KEMA Quality B.V.
Arnhem, July 15, 2010

F.S. Strikwerda
Certification Manager

© Integral publication of this certificate and adjoining reports is allowed

KEMA Quality B.V. Utrechtseweg 310, 6812 AR Arnhem P.O. Box 5185, 6802 ED Arnhem, The Netherlands
T +31 26 356 2000 F +31 26 352 5800 www.kemaquality.com Company registration 09085396

DEKRA company

KEMA Quality

TEST CERTIFICATE

No. 3301248.102

Issued to: DELTA ELECTRIC
P. O. Box No. 121 080
SHARJAH
UNITED ARAB EMIRATES (U.A.E)

For the product: low-voltage busbar trunking system (copper bar)

Trade name: DELTABAR

Type/Model: DELTABAR 1350
Copper busbar trunking system without tap off outlet

Ratings: Ue 1000 V, Ui 1000 V, Uimp 8 kV, In 1350 A at 50 Hz / 1250 A at 60 Hz,
low 65 kA – 1.0 s

Manufactured by: DELTA ELECTRIC
P. O. Box No. 121 080
SHARJAH
UNITED ARAB EMIRATES (U.A.E)

Subject: Type tests

Requirements: IEC 60439-2, 3rd ed. 2000-03 and Amendment A1 2005-08
Clauses: 8.2.1, 8.2.2, 8.2.3, 8.2.4, 8.2.5, 8.2.7, 8.2.9, 8.2.10, 8.2.12, 8.2.13,
8.2.14 and 8.2.15

Remarks: Clauses 8.2.6, 8.2.8 and 8.2.11 are not applicable for this type of product

This Test Certificate is granted on account of an examination by KEMA Quality, the results of which are laid down in report no. 3301248.03, dated July 15, 2010.

The examination has been carried out on one single specimen of the product, submitted by the manufacturer. The Attestation does not include an assessment of the manufacturer's production. Conformity of his production with the specimen tested by KEMA Quality is not the responsibility of KEMA Quality

KEMA Quality B.V.
Arnhem, July 15, 2010

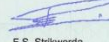
F.S. Strikwerda
Certification Manager

© Integral publication of this certificate and adjoining reports is allowed

KEMA Quality B.V. Utrechtseweg 310, 6812 AR Arnhem P.O. Box 5185, 6802 ED Arnhem, The Netherlands
T +31 26 356 2000 F +31 26 352 5800 www.kemaquality.com Company registration 09085396

DEKRA company

KEMA Quality

TEST CERTIFICATE

No. 3301248.105

Issued to: DELTA ELECTRIC
P. O. Box No. 121 080
SHARJAH
UNITED ARAB EMIRATES (U.A.E)

For the product: low-voltage busbar trunking system (copper bar)

Trade name: DELTABAR

Type/Model: DELTABAR 1600
Copper busbar trunking system without tap off outlet

Ratings: Ue 1000 V, Ui 1000 V, In 1600 A at 50 Hz / 1500 A at 60 Hz,
low 65 kA – 1.0 s

Manufactured by: DELTA ELECTRIC DELTA ELECTRIC
P. O. Box No. 121 080
SHARJAH
UNITED ARAB EMIRATES (U.A.E)

Subject: Type tests

Requirements: IEC 60439-2, 3rd ed. 2000-03 and Amendment A1 2005-08
Clauses: 8.2.1, 8.2.2, 8.2.3, 8.2.4, 8.2.5, 8.2.7, 8.2.9, 8.2.10, 8.2.12, 8.2.13,
8.2.14 and 8.2.15

Remarks: Clauses 8.2.6, 8.2.8 and 8.2.11 are not applicable for this type of product

This Test Certificate is granted on account of an examination by KEMA Quality, the results of which are laid down in report no. 3301248.06 dated July 15, 2010.

The examination has been carried out on one single specimen of the product, submitted by the manufacturer. The Attestation does not include an assessment of the manufacturer's production. Conformity of his production with the specimen tested by KEMA Quality is not the responsibility of KEMA Quality

KEMA Quality B.V.
Arnhem, July 15, 2010

F.S. Strikwerda
Certification Manager

© Integral publication of this certificate and adjoining reports is allowed

KEMA Quality B.V. Utrechtseweg 310, 6812 AR Arnhem P.O. Box 5185, 6802 ED Arnhem, The Netherlands
T +31 26 356 2000 F +31 26 352 5800 www.kemaquality.com Company registration 09085396

DEKRA company

KEMA Quality

TEST CERTIFICATE

No. 3301248.106

Issued to: DELTA ELECTRIC
P. O. Box No. 121 080
SHARJAH
UNITED ARAB EMIRATES (U.A.E)

For the product: low-voltage busbar trunking system (copper bar)

Trade name: DELTABAR

Type/Model: DELTABAR 2000
Copper busbar trunking system with and without tap off unit outlet

Ratings: Busbar: Ue 1000 V, Ui 1000 V, Uimp 8 kV, In 2000 A at 50 Hz /
1900 A at 60 Hz, low 85 kA – 1.0 s
Tap-off unit: Ue 415 V, Ui 690 V, Uimp 8 kV, In 630 A, Icc 20 kA at 415 V

Manufactured by: DELTA ELECTRIC
P. O. Box No. 121 080
SHARJAH
UNITED ARAB EMIRATES (U.A.E)

Subject: Type tests

Requirements: IEC 60439-2, 3rd ed. 2000-03 and Amendment A1 2005-08
Clauses: 8.2.1, 8.2.2, 8.2.3, 8.2.4, 8.2.5, 8.2.6, 8.2.7, 8.2.9, 8.2.10, 8.2.12,
8.2.13, 8.2.14 and 8.2.15

Remarks: Clauses 8.2.8 and 8.2.11 are not applicable for this type of product

This Test Certificate is granted on account of an examination by KEMA Quality, the results of which are laid down in report no. 3301248.07 dated July 15, 2010.

The examination has been carried out on one single specimen of the product, submitted by the manufacturer. The Attestation does not include an assessment of the manufacturer's production. Conformity of his production with the specimen tested by KEMA Quality is not the responsibility of KEMA Quality

KEMA Quality B.V.
Arnhem, July 15, 2010

F.S. Strikwerda
Certification Manager

© Integral publication of this certificate and adjoining reports is allowed

KEMA Quality B.V. Utrechtseweg 310, 6812 AR Arnhem P.O. Box 5185, 6802 ED Arnhem, The Netherlands
T +31 26 356 2000 F +31 26 352 5800 www.kemaquality.com Company registration 09085396

DEKRA company

KEMA Quality

ATTESTATION OF CONFORMITY

No.: 3301248.13A
 Issued to: DELTA ELECTRIC
 P. O. Box No. 121 080
 SHARJAH
 UNITED ARAB EMIRATES (U.A.E)
 Product: Box of tap off unit
 Trade name(s): DELTABAR
 Type(s)/model(s): Box of tap off unit 250 A / 400 A / 630 A
 Ratings: IP 66
 Manufactured by: DELTA ELECTRIC
 P. O. Box No. 121 080
 SHARJAH
 UNITED ARAB EMIRATES (U.A.E)
 Subject: Tests of Clauses: 8.2.7
 Requirements: IEC 60439-2, 3rd ed. 2000-03 and Amendment A1 2005-08

This Attestation is granted on account of an examination by KEMA Quality, the results of which are laid down in a test report No. 3301248.13, dated July 15, 2010.

The examination has been carried out on one single specimen of the product, submitted by the manufacturer. The Attestation does not include an assessment of the manufacturer's production. Conformity of his production with the specimen tested by KEMA Quality is not the responsibility of KEMA Quality.

Arnhem, July 15, 2010

KEMA Quality B.V.

 F.S. Strikwerda
 Certification Manager

KEMA Quality B.V. Utrechtseweg 310, 6812 AR Arnhem P.O. Box 5185, 6802 ED Arnhem, The Netherlands
 T +31 26 356 2000 F +31 26 352 5800 www.kemaquality.com Company registration 09068396



KEMA Quality

TEST CERTIFICATE

No. 3301248.107
 Issued to: DELTA ELECTRIC
 P. O. Box No. 121 080
 SHARJAH
 UNITED ARAB EMIRATES (U.A.E)
 For the product: low-voltage busbar trunking system (copper bar)
 Trade name: DELTABAR
 Type/Model: DELTABAR 2500
 Copper busbar trunking system without tap off outlet
 Ratings: Ue 1000 V, Ui 1000 V, Uimp 8 kV, In 2500 A at 50 Hz / 2350 A at 60 Hz, low 100 kA – 1.0 s
 Manufactured by: DELTA ELECTRIC
 P. O. Box No. 121 080
 SHARJAH
 UNITED ARAB EMIRATES (U.A.E)
 Subject: Type tests
 Requirements: IEC 60439-2, 3rd ed. 2000-03 and Amendment A1 2005-08
 Clauses: 8.2.1, 8.2.2, 8.2.3, 8.2.4, 8.2.5, 8.2.7, 8.2.9, 8.2.10, 8.2.12, 8.2.13, 8.2.14 and 8.2.15
 Remarks: Clauses 8.2.6, 8.2.8 and 8.2.11 are not applicable for this type of product

This Test Certificate is granted on account of an examination by KEMA Quality, the results of which are laid down in report no. 3301248.09 dated July 15, 2010.

The examination has been carried out on one single specimen of the product, submitted by the manufacturer. The Attestation does not include an assessment of the manufacturer's production. Conformity of his production with the specimen tested by KEMA Quality is not the responsibility of KEMA Quality.

KEMA Quality B.V.
 Arnhem, July 15, 2010

 F.S. Strikwerda
 Certification Manager

KEMA Quality B.V. Utrechtseweg 310, 6812 AR Arnhem P.O. Box 5185, 6802 ED Arnhem, The Netherlands
 T +31 26 356 2000 F +31 26 352 5800 www.kemaquality.com Company registration 09068396



KEMA Quality

TEST CERTIFICATE

No. 3301248.108
 Issued to: DELTA ELECTRIC
 P. O. Box No. 121 080
 SHARJAH
 UNITED ARAB EMIRATES (U.A.E)
 For the product: low-voltage busbar trunking system (copper bar)
 Trade name: DELTABAR
 Type/Model: DELTABAR 3000
 Copper busbar trunking system without tap off outlet
 Ratings: Ue 1000 V, Ui 1000 V, Uimp 8 kV, In 3000 A at 50 Hz / 2850 A at 60 Hz, low 100 kA – 1.0 s
 Manufactured by: DELTA ELECTRIC
 P. O. Box No. 121 080
 SHARJAH
 UNITED ARAB EMIRATES (U.A.E)
 Subject: Type tests
 Requirements: IEC 60439-2, 3rd ed. 2000-03 and Amendment A1 2005-08
 Clauses: 8.2.1, 8.2.2, 8.2.3, 8.2.4, 8.2.5, 8.2.7, 8.2.9, 8.2.10, 8.2.12, 8.2.13, 8.2.14 and 8.2.15
 Remarks: Clauses 8.2.6, 8.2.8 and 8.2.11 are not applicable for this type of product

This Test Certificate is granted on account of an examination by KEMA Quality, the results of which are laid down in report no. 3301248.09 dated July 15, 2010.

The examination has been carried out on one single specimen of the product, submitted by the manufacturer. The Attestation does not include an assessment of the manufacturer's production. Conformity of his production with the specimen tested by KEMA Quality is not the responsibility of KEMA Quality.

KEMA Quality B.V.
 Arnhem, July 15, 2010

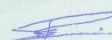
 F.S. Strikwerda
 Certification Manager

KEMA Quality B.V. Utrechtseweg 310, 6812 AR Arnhem P.O. Box 5185, 6802 ED Arnhem, The Netherlands
 T +31 26 356 2000 F +31 26 352 5800 www.kemaquality.com Company registration 09068396



KEMA Quality

TEST CERTIFICATE

No. 3301248.109
 Issued to: DELTA ELECTRIC
 P. O. Box No. 121 080
 SHARJAH
 UNITED ARAB EMIRATES (U.A.E)
 For the product: low-voltage busbar trunking system (copper bar)
 Trade name: DELTABAR
 Type/Model: DELTABAR 3200
 Copper busbar trunking system without tap off outlet
 Ratings: Ue 1000 V, Ui 1000 V, Uimp 8 kV, In 3200 A at 50 Hz / 3000 A at 60 Hz, low 100 kA – 1.0 s
 Manufactured by: DELTA ELECTRIC
 P. O. Box No. 121 080
 SHARJAH
 UNITED ARAB EMIRATES (U.A.E)
 Subject: Type tests
 Requirements: IEC 60439-2, 3rd ed. 2000-03 and Amendment A1 2005-08
 Clauses: 8.2.1, 8.2.2, 8.2.3, 8.2.4, 8.2.5, 8.2.7, 8.2.9, 8.2.10, 8.2.12, 8.2.13, 8.2.14 and 8.2.15
 Remarks: Clauses 8.2.6, 8.2.8 and 8.2.11 are not applicable for this type of product

This Test Certificate is granted on account of an examination by KEMA Quality, the results of which are laid down in report no. 3301248.10 dated July 15, 2010.

The examination has been carried out on one single specimen of the product, submitted by the manufacturer. The Attestation does not include an assessment of the manufacturer's production. Conformity of his production with the specimen tested by KEMA Quality is not the responsibility of KEMA Quality.

KEMA Quality B.V.
 Arnhem, July 15, 2010

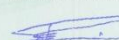
 F.S. Strikwerda
 Certification Manager

KEMA Quality B.V. Utrechtseweg 310, 6812 AR Arnhem P.O. Box 5185, 6802 ED Arnhem, The Netherlands
 T +31 26 356 2000 F +31 26 352 5800 www.kemaquality.com Company registration 09068396



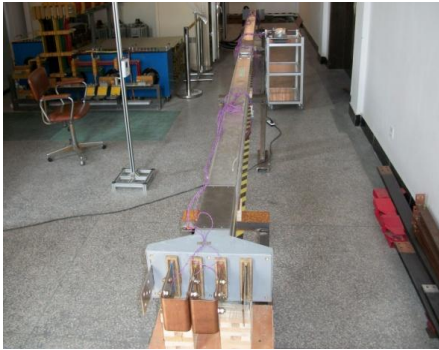

Clause 8.2.1.3a : Verification of Temperature rise Limits – Feeder Elements without Tap-off Unit



Clause 8.2.1.3b : Verification of Temperature rise Limits – Feeder Elements with Tap-off Unit



Clause 8.2.1.8 : Thermal Cycling Test



Clause 8.2.2 : Verification of Dielectric Properties

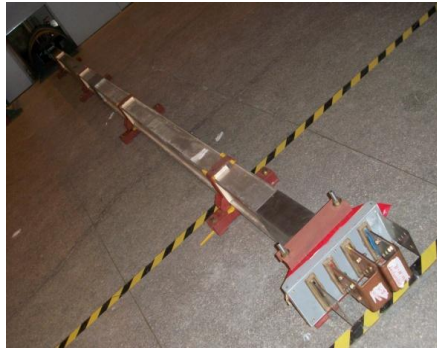

Clause 8.2.3 : Verification of short Circuit Strength (Icw)– Feeder Elements without Tap-off Unit



Clause 8.2.4.2 : Verification of effectiveness of the Protective Circuit (Icw) – Feeder Elements without Tap-off Unit



Clause 8.2.3.2.3a : Verification of Short Circuit Strength (Icc) - Feeder Elements without Tap-off Unit



Clause 8.2.4.2 : Verification of effectiveness of the Protective Circuit (Icc) – Feeder Elements without Tap-off Unit

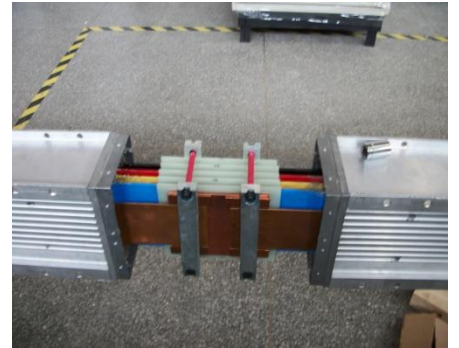

Clause 8.2.4.2 : Verification of effectiveness of the Protective Circuit (Icc) – Feeder Elements without Tap-off Unit



Clause 8.2.6 : Verification of Mechanical Operation



IP X8



IP 6X

Clause 8.2.7 : Verification of Degree of Protection – (Busbar)



Tracking Index Test

Clause 8.2.9 : Verification of the Resistance of Insulating Materials to Abnormal Heat and Fire

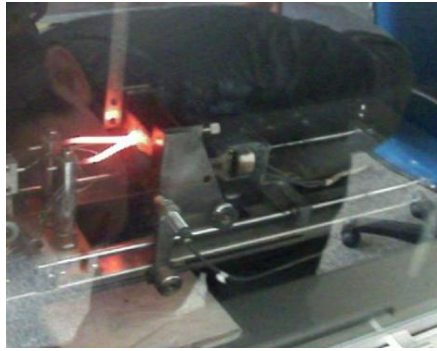

Glow-Wire Test



Clause 8.2.10 : Verification of Structural Strength
Clause 8.2.12 : Verification of Cushing Resistance



Clause 8.2.13 : Verification of Electrical Characteristics of Busbar Trunking System



Clause 8.2.14 : Verification Resistance to Flame Propagation



Clause 8.2.15 : Verification of Fire Resistance in Building Penetration



IEC 60331-3 : Test for Electric Cables under Fire Condition-Circuit Integrity (with Conductors Energised)

TYPICAL INSTALLATION

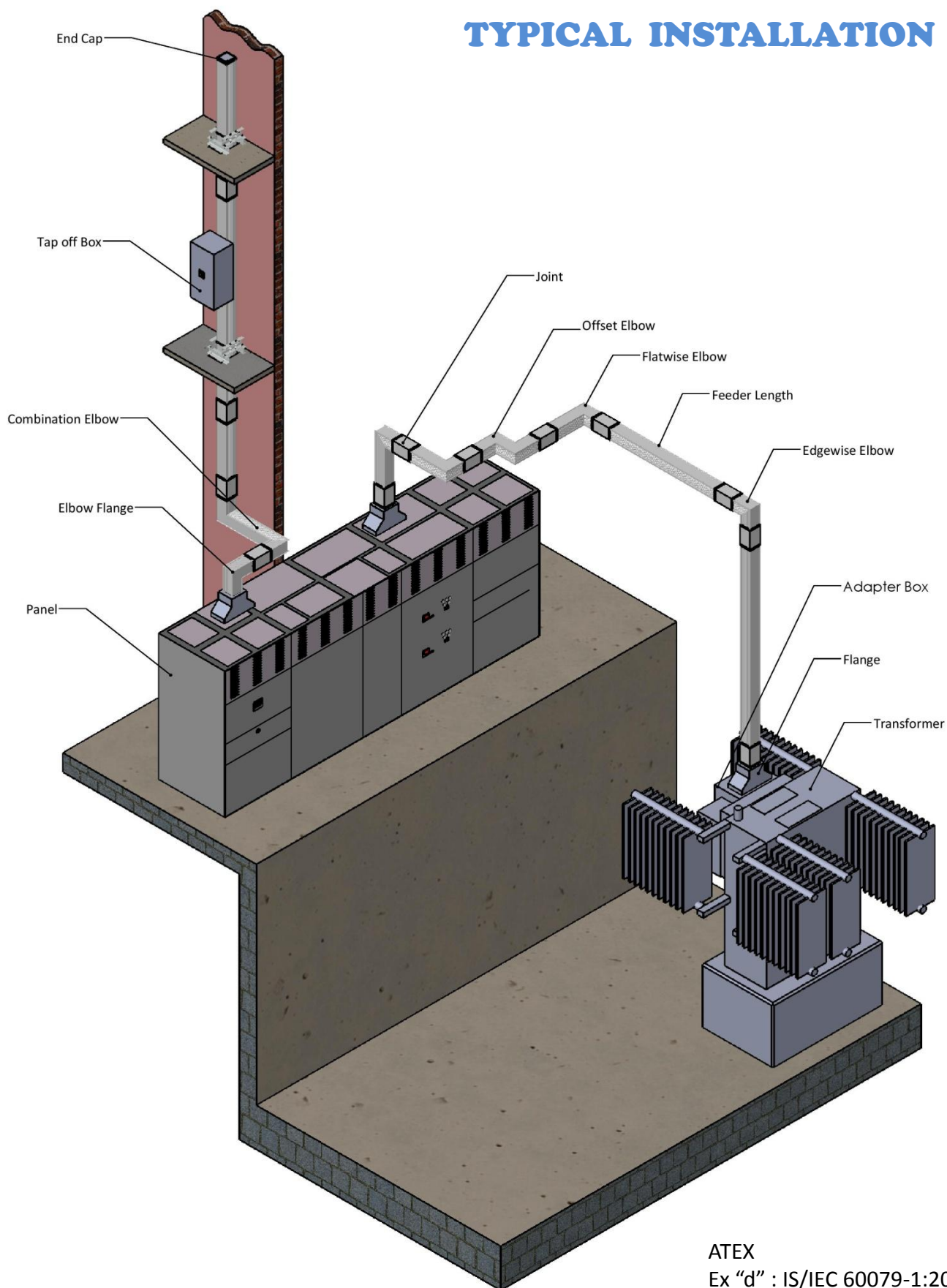

ATEX
Ex "d" : IS/IEC 60079-1:2007

OUR CLIENTS:-



DELTABAR®

MV/LV BUSWAY SYSTEMS



DELTA ELECTRIC Ltd

Unit 21 Bonville Business Centre
BS4 5QR Bonville Road, Bristol
United Kingdom
Tel:- +44117 980 1903
deltauk@deltaelectric.ws

DELTA ELECTRIC FZE

P.O Box :121080, SAIF Zone Sharjah
United Arab Emirates
Tel :- +971 6 5578823
Fax :- +971 6 5578824
info@deltaelectric.ws